

Instructions:

To build your robot you will need the following items: Sharp craft knife (a fresh blade makes a world of difference). Cutting mat or board. Steel rule. A scribe to score the folding lines (those blessed with a gentle touch can use the knife, but something blunt is best, a kitchen skewer or empty ball-point pen). Glue (Pritt-stick type is fine, but may be harder to stick delicate parts with, a white PVA glue applied with a cocktail stick is ideal but will take longer to dry secure). Scotch Tape (not essential, but may be useful). Something to drink (tea is best).

It isn't necessary to cut out all the parts at once, but always score the dotted lines before cutting out. The scoring should leave a definite impression in the card but not cut the surface. A few folds are in the opposite direction (valley as opposed to mountain folds), and these will benefit from extra pressure on the score, or re-scoring from the opposite site. Naturally this cannot be done until the part is cut out.

Make sure your hands are clean while gluing - be aware that the ink used on the card may be soluble in the glue and may get transferred to your fingers and then to the surface of the robot. This would obviously be disastrous.

Body

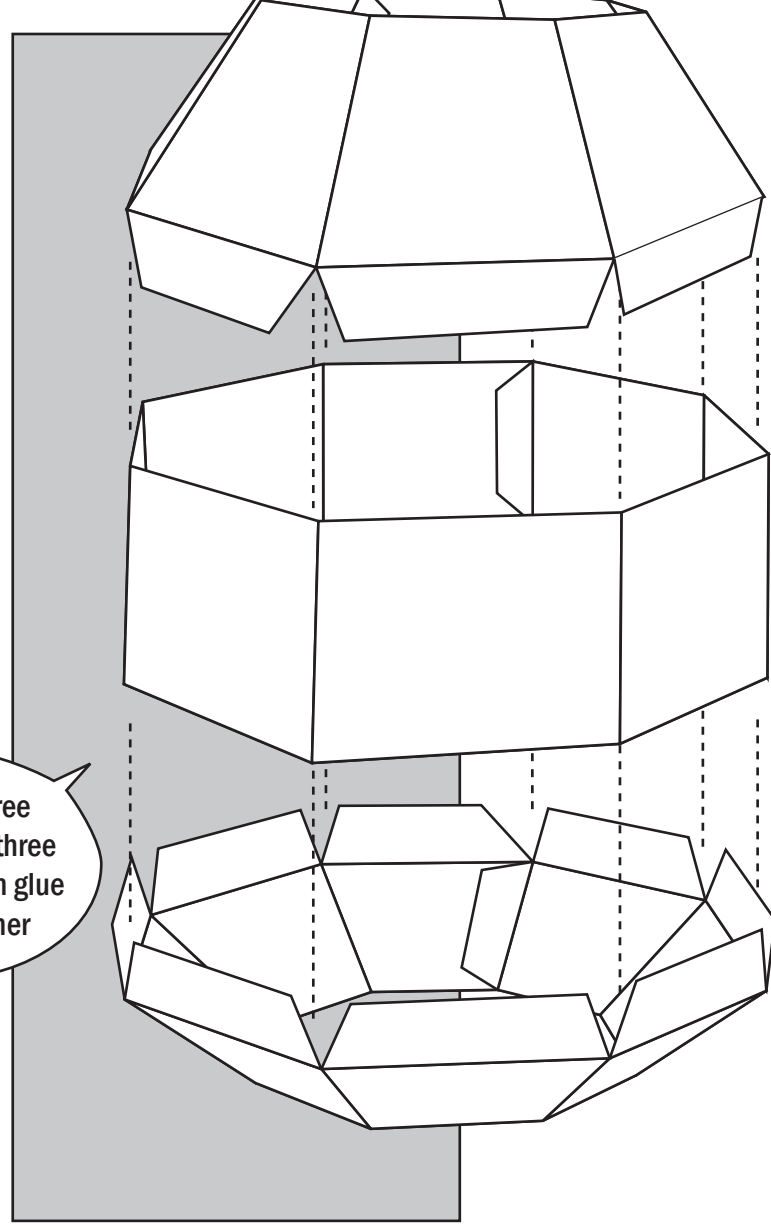

stick the three sections into three rings first, then glue them together

Fists

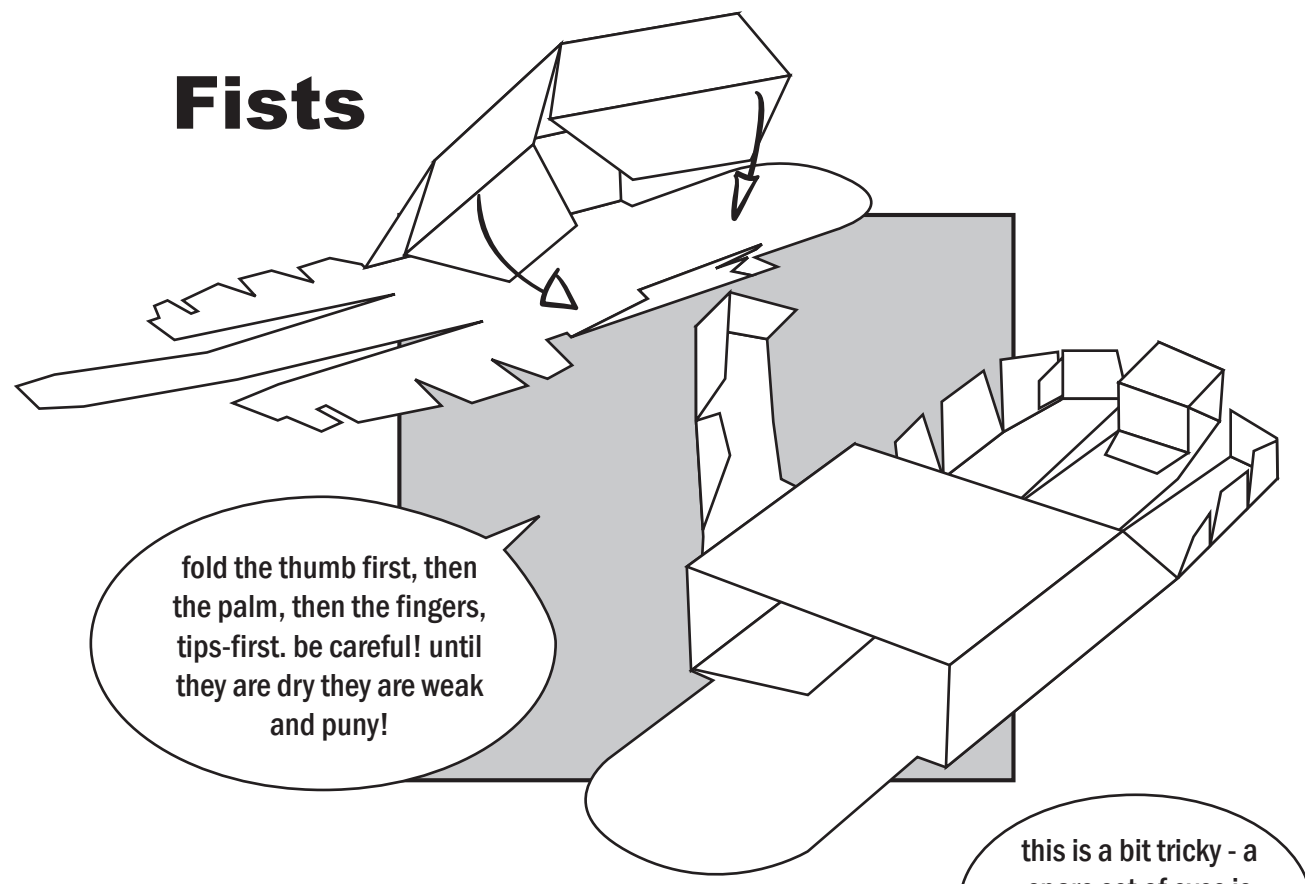

fold the thumb first, then the palm, then the fingers, tips-first. be careful! until they are dry they are weak and puny!

this is a bit tricky - a spare set of eyes is printed in the kit in case of mistakes!

Peeping Eyes

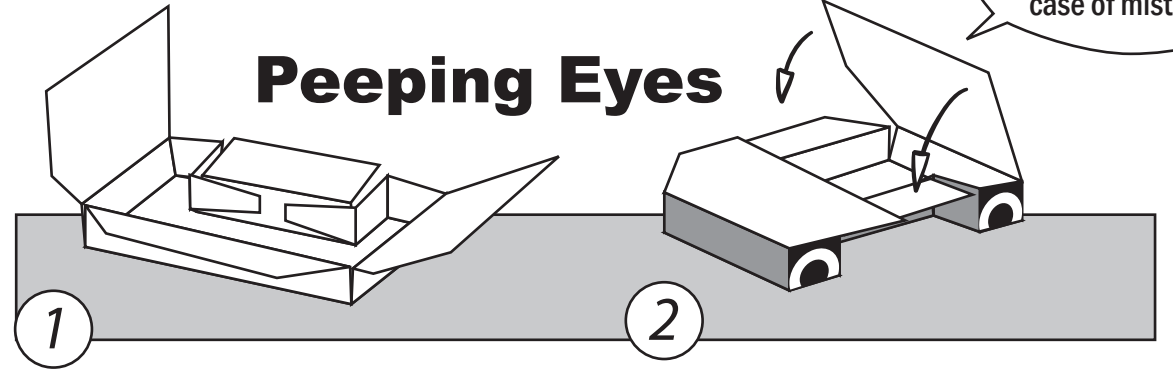

Legs

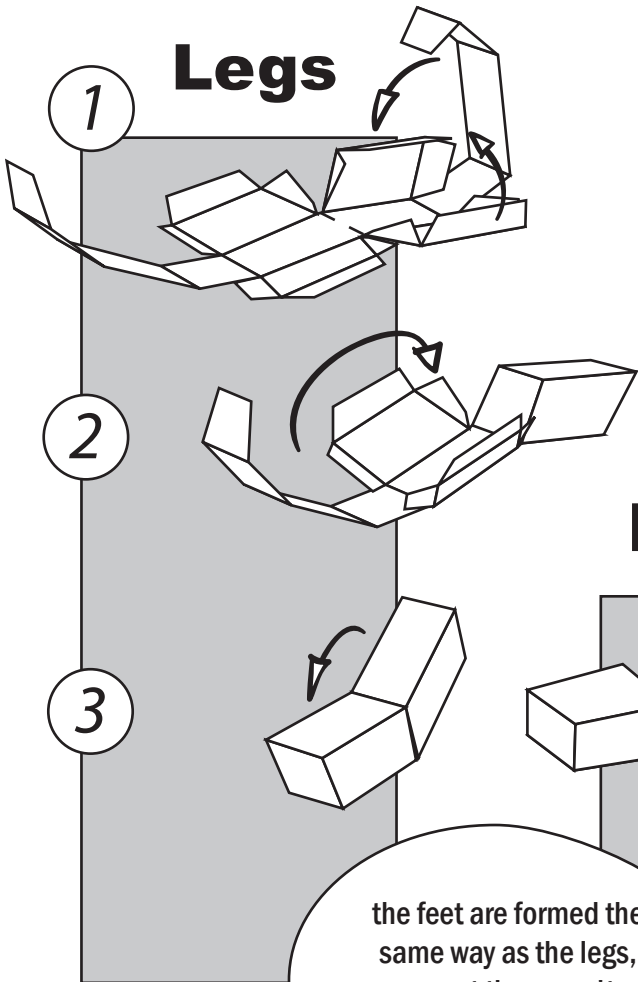

the feet are formed the same way as the legs, except they aren't glued into the bent knee shape.

Feet

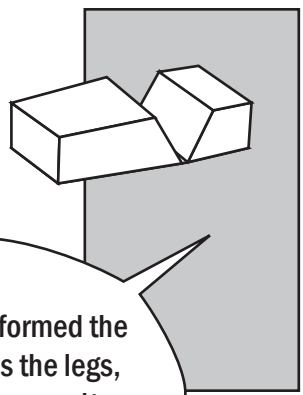

1

stick the inside detail onto the forearm before forming the shape.

Forearms

3

the outer flames artwork on the forearms should be applied carefully, only after the forearm has been formed and is dry

2

(upper-arms)

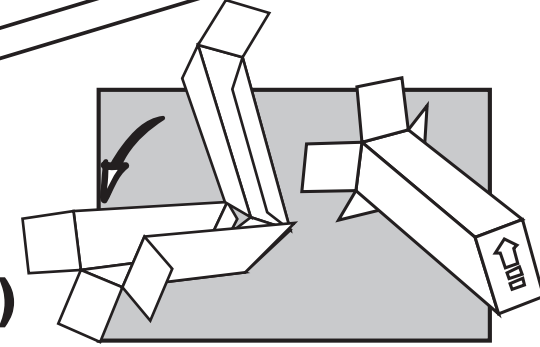

This Original Angry Robot No. 1 Kit is Copyright Sandy Noble 2009 www.uptomuch.co.uk

Shoulders

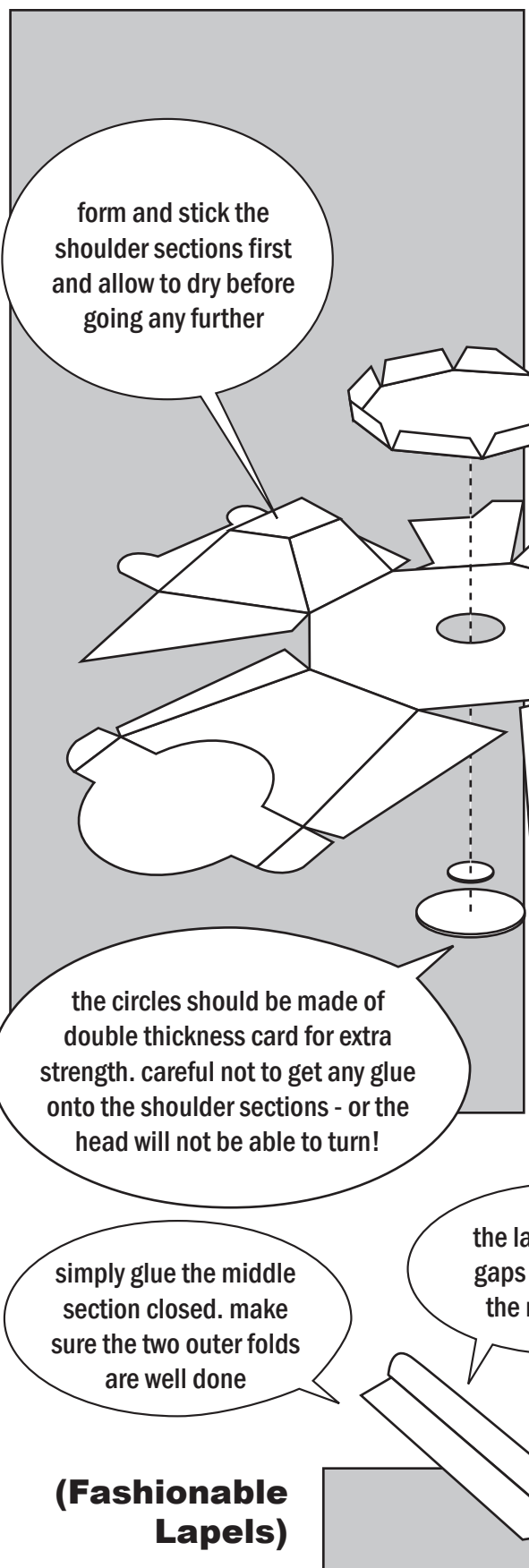

form and stick the shoulder sections first and allow to dry before going any further

the circles should be made of double thickness card for extra strength. careful not to get any glue onto the shoulder sections - or the head will not be able to turn!

simply glue the middle section closed. make sure the two outer folds are well done

(Fashionable Lapels)

the lapels fit in the gaps either side of the robots chest

Head

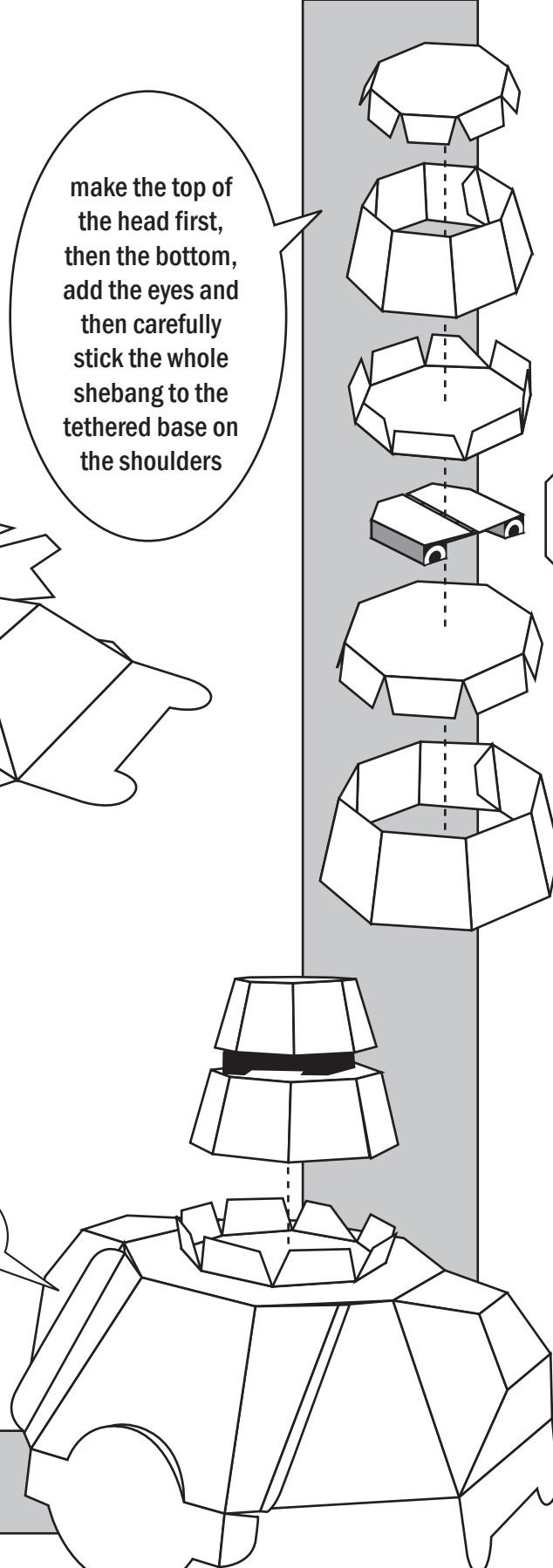

make the top of the head first, then the bottom, add the eyes and then carefully stick the whole shebang to the tethered base on the shoulders

position so that eyeballs line up with the edge of the top of the head.

Attaching the feet to the legs is straightforward.

There are indicators on the base of the body to show where the tops of the legs should be glued, as well as arrows to show their direction.

the front of the legs is indicated by an extended mark over the fold to help in orientating it correctly with the body

Assembly

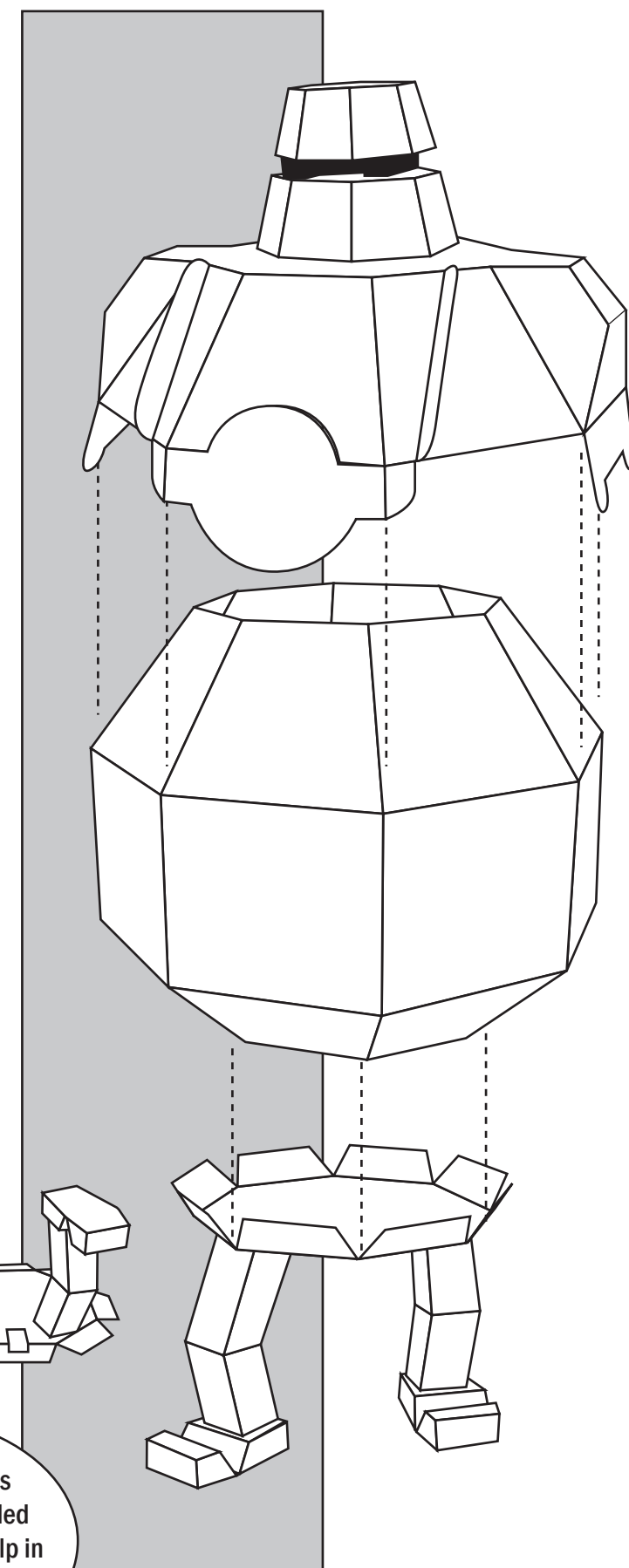

Arm Alignment

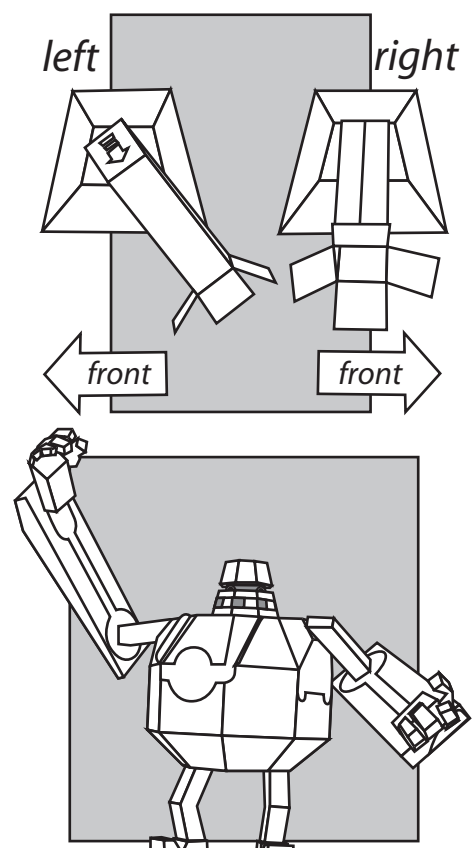

Apply plenty of pressure while the upper-arms dry (the shoulder joint is the weakest part of the robot - scotch tape may be useful in holding the joint tight) and do not be hasty in fitting the forearms. They are heavy and require good support. When you have decided how to pose them, stick them one at a time, and leave a good few minutes in between arms.

Once the robot is completed, you should find he stands up unassisted, brandishing his mighty fists like some kind of maniacal mechanised monkey. (In the event of an overbalance, a base may be made from a sheet of stiff cardboard to allow the robots dynamic pose to be appreciated without unsightly and undignified toppling.)

At this point the robots terrifying grin should be added to activate his anger at his thoughtless and uncaring creators.